

# 內徑倒角刀 Internal Chamfering Blade

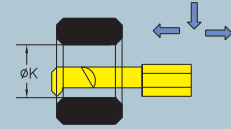
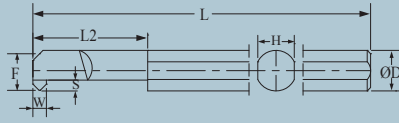
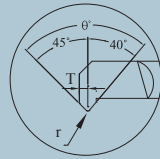
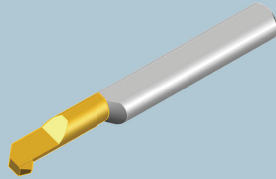

型號 EDP NO.	$\theta^\circ$	ØK	F	T	W	L2	L	r	S	ØD	在庫 stock	適用套筒 Applicable Sleeve
57.4010-2002	85	4	3.8	1.0	2.0	10	40	0.2	1.0	4	●	SP.250-04**
57.4015-2002	85	4	3.8	1.0	2.0	15	45	0.2	1.0	4	●	SP.5650-04**
57.6015-2502	85	6	5.8	1.25	2.5	15	50	0.2	1.5	6	●	SP.250-06**
57.6025-2502	85	6	5.8	1.25	2.5	25	60	0.2	1.5	6	●	SP.5650-06**
57.8020-3002	85	8	7.8	1.5	3.0	20	60	0.2	2.0	8	●	SP.250-08**
57.8030-3002	85	8	7.8	1.5	3.0	30	70	0.2	2.0	8	●	SP.5650-08**
57.10025-3002	85	10	9.8	1.5	3.0	25	70	0.2	2.5	10		SP.250-10**
57.10040-3002	85	10	9.8	1.5	3.0	40	85	0.2	2.5	10		SP.5650-10**
57.4010S-2002	90	4	3.8	1.0	2.0	10	40	0.2	1.0	4		SP.250-04**
57.4015S-2002	90	4	3.8	1.0	2.0	15	45	0.2	1.0	4		SP.5650-04**
57.6015S-2502	90	6	5.8	1.25	2.5	15	50	0.2	1.5	6		SP.250-06**
57.6025S-2502	90	6	5.8	1.25	2.5	25	60	0.2	1.5	6		SP.5650-06**
57.8020S-3002	90	8	7.8	1.5	3.0	20	60	0.2	2.0	8		SP.250-08**
57.8030S-3002	90	8	7.8	1.5	3.0	30	70	0.2	2.0	8		SP.5650-08**
57.10025S-3002	90	10	9.8	1.5	3.0	25	70	0.2	2.5	10		SP.250-10**
57.10040S-3002	90	10	9.8	1.5	3.0	40	85	0.2	2.5	10		SP.5650-10**

無"●"標示者為訂製品。Without "●" marking means custom products.  
 有"●"標示者為在庫品。With "●" marking means items in stock.

# 内徑倒角刀 Internal Chamfering Blade

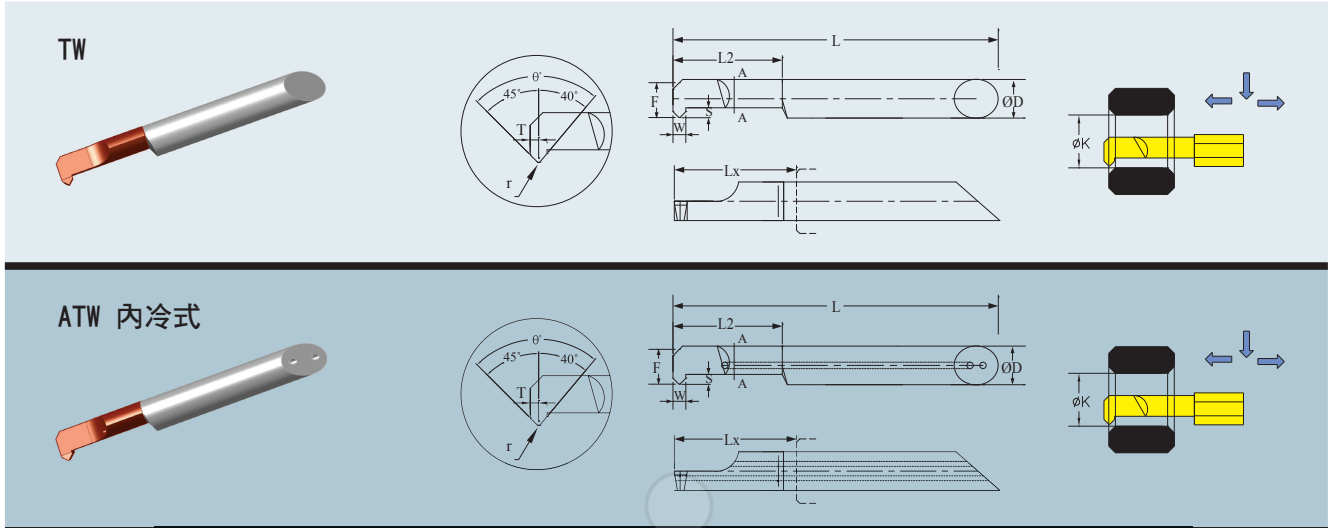

型號 EDP NO.	内冷式 型號 EDP NO.	$\theta^\circ$	$\varnothing K$	F	t	W	L2	Lx	r	S	$\varnothing D$	在庫 stock	適用套筒 Applicable Sleeve
TW 57.4010-2002	ATW 57.4010-2002	85	4	3.8	1.0	2.0	10	12	0.2	1.0	4		SP.380-04**
TW 57.4015-2002	ATW 57.4015-2002	85	4	3.8	1.0	2.0	15	17	0.2	1.0	4		SP.380-04**
TW 57.6015-2502	ATW 57.6015-2502	85	6	5.8	1.25	2.5	15	18	0.2	1.5	6		SP.380-06**
TW 57.6025-2502	ATW 57.6025-2502	85	6	5.8	1.25	2.5	25	28	0.2	1.5	6		SP.380-06**
TW 57.8020-3002	ATW 57.8020-3002	85	8	7.8	1.5	3.0	20	23	0.2	2.0	8		SP.380-08**
TW 57.8030-3002	ATW 57.8030-3002	85	8	7.8	1.5	3.0	30	33	0.2	2.0	8		SP.380-08**
TW 57.4010S-2002	ATW 57.4010S-2002	90	4	3.8	1.0	2.0	10	12	0.2	1.0	4		SP.380-04**
TW 57.4015S-2002	ATW 57.4015S-2002	90	4	3.8	1.0	2.0	15	17	0.2	1.0	4		SP.380-04**
TW 57.6015S-2502	ATW 57.6015S-2502	90	6	5.8	1.25	2.5	15	18	0.2	1.5	6		SP.380-06**
TW 57.6025S-2502	ATW 57.6025S-2502	90	6	5.8	1.25	2.5	25	28	0.2	1.5	6		SP.380-06**
TW 57.8020S-3002	ATW 57.8020S-3002	90	8	7.8	1.5	3.0	20	23	0.2	2.0	8		SP.380-08**
TW 57.8030S-3002	ATW 57.8030S-3002	90	8	7.8	1.5	3.0	30	33	0.2	2.0	8		SP.380-08**

無"●"標示者為訂製品。Without "●" marking means custom products.  
 有"●"標示者為在庫品。With "●" marking means items in stock.